

• Technical

Preparation and Properties of Methyl Arachidonate from Pork Liver^{1,2}

O. S. PRIVETT, R. P. WEBER, and E. CHRISTENSE NICKELL, Hormel Institute, University of Minnesota, Austin, Minnesota

ALTHOUGH arachidonic acid is distributed widely in animal tissues, its isolation is difficult. There are several reasons for this; the most important is that it occurs in small concentrations with lipids of similar physical properties. It also is very susceptible to autoxidation, which further complicates its isolation. However relatively pure samples of arachidonic acid have been isolated by the bromination-debromination procedure (1, 2, 13, 16) and by a combination of physical methods of separation (7, 13, 16, 19). Rich concentrates also have been prepared by the selective solubilities of lithium soaps in acetone (1, 18).

The purpose of this paper is to describe a procedure for the isolation of arachidonic acid and the fractionation of natural mixtures of fatty acids into specific groups from which the component acids may be isolated. Reported here is the process as it is applied to pork liver lipids.

General Procedure

Extraction of Fat. Two methods were used to extract the fat from the tissues. In one, fresh pork liver is vacuum-dried at 10–15°C. to 8–10% moisture, ground to a fine powder, and extracted with a 5:5:1 mixture of Skellysolve F (low boiling petroleum ether), ethyl ether, and ethanol. In the other method, the tissue is digested directly with alkali, and the fatty acids are liberated with HCl and extracted with Skellysolve F.

In the first method, about 4,000 g. of liver are placed in a 24-liter flask with about 9 liters of the mixed solvent. The mixture is heated on a steam bath under gentle reflux conditions. Because of the large amount of solvent used, it was not practicable, on a laboratory scale, to conduct more than three extractions on a single batch. In a typical extraction 3,850 g. of dried liver yielded successively 360, 126, and 36 g. of lipid. The recovered lipid (522 g.) is saponified with alcoholic KOH under an atmosphere of nitrogen, acidified with HCl, and extracted with Skellysolve F.

In the second method, fresh liver is ground and thoroughly mixed with KOH flakes (20 g. tissue/1 g. of KOH) and ethanol (1 kg. tissue/1 liter of ethanol); the mixture is warmed on a steam bath under an atmosphere of nitrogen until the tissue is completely dissolved. This requires about three hours. Although most of the fat is saponified in this time, the solution is allowed to stand over-night at room temperature to insure completion of the saponification.

The fatty acids are liberated from the alkali digest with 20% HCl. During the addition of HCl the solu-

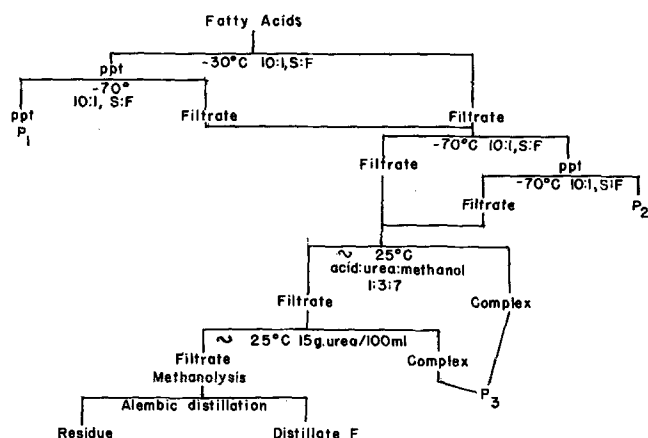

Fig. 1. Fractionation of pork liver fatty acids.

tion must be well stirred to avoid local heating, which results in undesirable boil-ups. Following the acidification, distilled water is added and a siphon is inserted to the bottom of the flask. The mixture is allowed to stand for about an hour, during which time the fat collects on top of the aqueous phase. The aqueous phase is siphoned off. The fatty layer is dissolved in Skellysolve F, transferred to a 6-liter separatory funnel, and washed two or three times with distilled water to remove the mineral acid and other water-soluble material. In a typical experiment 10 kg. of pork liver yielded 403 g. of fatty acids.

In either procedure the nonsaponifiables may be extracted with petroleum ether before acidification of the soaps. However, since pork liver fat contains only 4–5% of nonsaponifiable material, it is usually not removed unless there is some reason for isolating the nonsaponifiable material itself.

Fractionation of Fatty Acids. The fatty acids are separated into broad groups on the basis of their solubility in Skellysolve F at low temperatures and their formation of inclusion compounds with urea (Fig. 1). Crystallization from Skellysolve F at low temperature separates a fraction consisting mainly of saturated fatty acids (P_1 , Fig. 1) and monounsaturated acids (P_2 , Fig. 1). The soluble acids are then further fractionated by the addition of urea to permit the formation of inclusion compounds. This gives another fraction, also consisting mainly of monounsaturated acids (P_3 , Fig. 1). The filtrate contains the bulk of the polyunsaturated acids as well as the foreign materials extracted from the tissues and some of the nonsaponifiables, including cholesterol. Thus it is desirable to give this fraction a simple alembic distillation before fractionating it further. Before distillation it is converted to methyl esters by using dry HCl as a catalyst. The other fractions P_1 , P_2 ,

¹ This work is supported by funds from the Hormel Foundation.

² Presented at the fall meeting, American Oil Chemists' Society, Chicago, Ill., October 20–22, 1958.

TABLE I
Distillation of Fraction F, Figure 1—Reflux Ratio 20:1,
0.03 mm. of Pressure

Chain length	Fractions of distillate									Resi- due
	1-3	4	5-9	10	11-17	18-20	21-30	31-33	34-38	
C-14	+									
C-16	+	+								
C-18			+	+						
C-20					+					
C-22						+	+	+	+	
%	1.0	0.5	4.8	1.0	37.3	3.0	37.5	3.1	9.8	3.4
Pot temperatures of main fractions:										
C-14	150-155°C.				C-20	183-195°C.				
C-16	160-165				C-22	200				
C-18	170-178									

and P₃ also are converted to methyl esters in a similar manner. The next step is to separate all the fractions (P₁, P₂, P₃, and F) into their single chain-length components by distillation through a spinning-band column.

Fractional Distillation. In order to minimize alteration of the higher polyunsaturated fatty acid esters, a slightly modified distillation technique was employed. The distillation was performed in a Podbielniak whirling-band column at as high a vacuum as possible, usually 25 to 30 microns at the head of the column. A reflux ratio of 20:1 was maintained during the distillation of the main body of a chain-length fraction and 30:1 during the transition from one chain length to another. The pot temperature was adjusted so that only fractions of the lowest chain-length would distill. Under these conditions, toward the end of the distillation of a chain-length fraction, the head temperature dropped, and finally the distillation came to a virtual standstill. Then, with a reflux ratio of 30:1, the pot temperature was raised slowly, and the intermediate fractions were collected. These fractions, sometimes only a few drops, were analyzed for chain length by paper (15) or gas-liquid chromatography (GLC). Table I shows the results of the distillation of fraction F, Figure 1, by this technique, using paper chromatographic analyses to determine chain length. Since GLC can be applied directly on the distillate, in more recent distillations the progress of the fractionation was followed by means of a special sampling device placed above the fraction cutter. This device (Figure 2) permitted the removal of a drop of distillate at any time without interruption of the distillation.

Each of the chain-length fractions obtained from the distillation of P₁, P₂, P₃, and F was analyzed by gas-liquid chromatography, paper chromatography (15), or alkali-isomerization (8), or a combination of all three methods, depending on their complexity. From these analyses the composition of P₁, P₂, P₃, and F was determined (Table II) as well as the composition of the original acids. These analyses (Table II) showed that the major acids of pork liver are palmitic, stearic, oleic, linoleic, and arachidonic. In addition, a wide assortment of fatty acids with varying degrees of unsaturation were detected in minor amounts. These also are listed in Table II. The four minor components of the C-20 chain-length series and the four components of the C-22 series were identified by GLC and alkali-isomerization analyses. Trace amounts of 10, 11, 12, 13, 14, 15, 17, and 19 carbon-chain acids, some of which appeared to be unsatu-

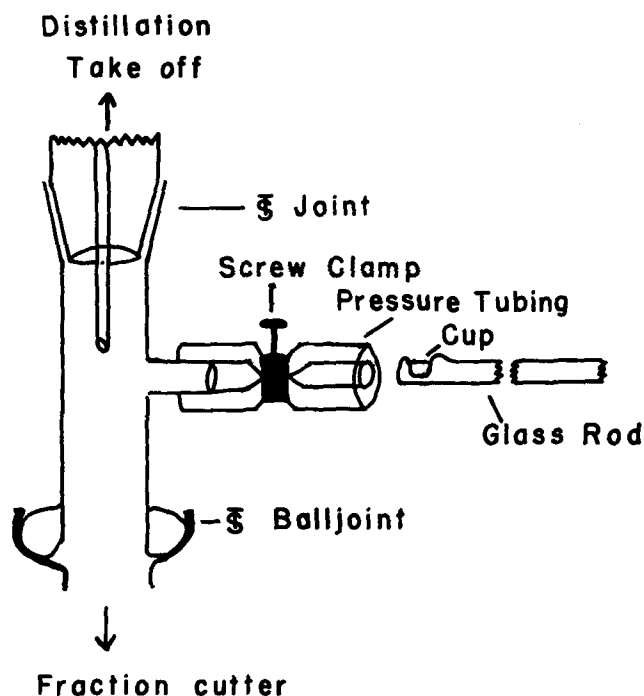

FIG. 2. Distillate sampling device.

rated, also were detected, but no effort was made to quantitate them. The GLC analysis of the first distillate of fraction F, which consisted of a mixture of low chain-length acids, is shown in Figure 3.

In addition to the acids of known structure, isomers of arachidonic, linoleic, and palmitoleic acids appeared to be present, as indicated by the GLC analyses shown in Figures 3 and 6. Because their structures are unknown, they are listed simply as isomers.

Four compounds were detected by GLC in the C-22 polyunsaturated fraction. Alkali-isomerization showed that two of these were pentaenoic and hexaenoic acids. The other two were believed to be tri- and diunsaturated acids, on the basis of their retention times with respect to the pentaenoic and hexaenoic acids. The possibility that one of these is a tetraenoic acid cannot be excluded however.

TABLE II
Fatty Acid Composition of Pork Liver Lipid

Analyses	Fractions, Figure 1				Calculated F. A. composition of original
	P ₁	P ₂	P ₃	F	
Percentage of original.....	%	%	%	%	%
First distillate fraction ^a	33.0	37.4	15.5	12.4
Palmitic.....	40.3	1.3	1.5	1.5	0.9
Stearic.....	51.0	15.3	19.9	0.1	22.9
Palmitoleic.....		trace	trace		16.8
Isomeric palmitoleic.....				4.9	0.6
Palmitolinoleic.....				0.5	0.6
Oleic.....	2.3	73.2	64.0	5.8	38.5
Linoleic.....		2.0	3.8	29.6	5.0
Isomeric linoleic.....				2.0	0.2
Octadecatenoic.....			1.0	1.4	0.3
Eicosaenoic.....				0.2
Icosadienoic.....				2.0	0.2
Eicosatrienoic.....				2.5	0.3
Arachidonic.....			trace	35.4	4.4
Isomeric arachidonic.....				1.4	0.2
Eicosapentaenoic.....				1.1	0.2
Docosadienoic.....				3.3	0.4
Docosatrienoic.....				1.1	0.2
Docosapentaenoic.....				3.4	0.4
Docosahexaenoic.....				2.2	0.3
Nondistillable fraction.....	6.4	8.0	7.4	3.4	6.7

^a Myristic and lower chain length material.

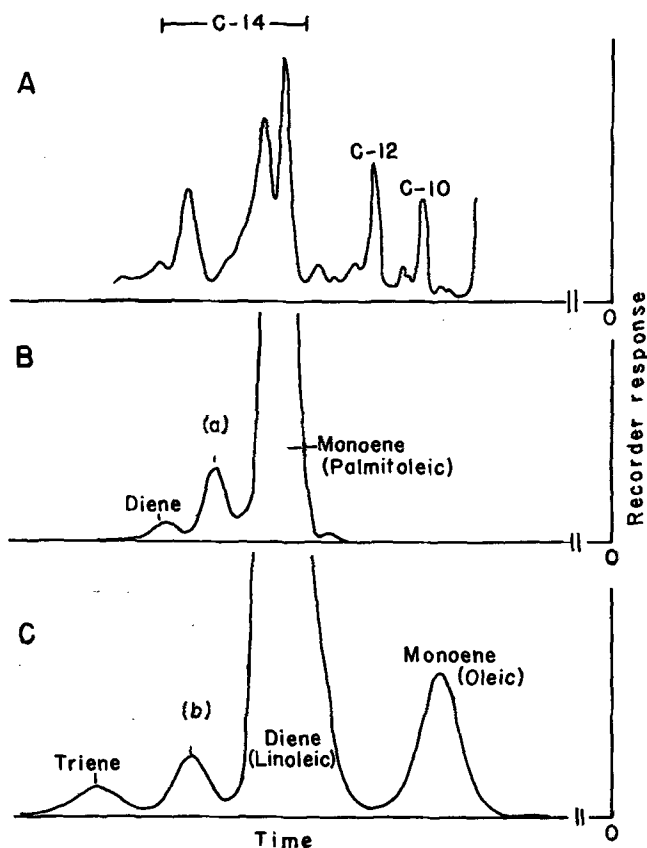

FIG. 3. GLC analysis of distillate fractions of fraction F, Fig. 1. A = first distillate fraction; B = C-16 chain length material; C = C-18 chain length material. Peak (a) is isomer of palmitoleic; peak (b) is isomer of linoleic.

The GLC analysis in Figures 3 and 6 were obtained through the courtesy of W. E. Link in the laboratories of the Archer-Daniels-Midland Company, using thermal detection with the Craig polyester (succinate polyester of butanediol-1,4) as the stationary phase.

Isolation of Methyl Arachidonate. Methyl arachidonate was isolated by the scheme shown in Figure 4 from the C-20 chain-length material separated from fraction F, Figure 1, by fractional distillation. In addition to methyl arachidonate, this fraction contained small amounts of methyl eicosapentaenoate, eicosatrienoate, eicosadienoate, eicosanoate, and an isomer of methyl arachidonate (Figure 6). The first step in the procedure was to separate the methyl eicosapentaenoate by adsorption chromatography, using the same conditions Hammond and Lundberg (6) described for the isolation of methyl docosahexaenoate. Methyl eicosapentaenoate has a much stronger affinity for silica gel than methyl arachidonate, and thus the methyl arachidonate (and lower unsaturated C-20 esters) emerge from the column first on elution with petroleum ether that contains a small amount of ethyl ether (usually about 0.5%). Removal of the pentaenoate impurity was monitored by alkali-isomerization analysis (Figure 5) and paper chromatography. Only a single spot was visible to the naked eye for the C-20 distillate fraction as well as for the chromatographically purified sample by the iodine-staining technique of paper chromatographic analyses for unsaturated fatty esters (15). However, when the uniformity of the spot was determined by density measurements, the small amount of methyl

eicosapentaenoate in the C-20 distillate fraction was detected.

Following removal of the pentaene, the methyl arachidonate concentrate was further purified by urea fractionation (Figure 4) according to the following procedure. First, the sample was dissolved in ethanol to give a 10% solution. This was mixed with an equal volume of warm ethanol containing 10% urea. The solutions were mixed together in a suction flask connected to a two-way stopper, flushed several times with pure nitrogen, and allowed to cool over-night under a negative pressure of nitrogen. The urea complexes which formed were separated by filtration (B, Figure 4). The filtrate was placed in a refrigerator at 0°C., and another crop of adducts was obtained (C, Figure 4). Still another crop of adducts was obtained on dissolving more urea in the filtrate and lowering the temperature to -15°C. (D, Figure 4). The yield of methyl arachidonate may be further increased by repeating this latter treatment on the filtrate (E, Figure 4) or by taking another crop of adducts at a still lower temperature. The usual practice however was to combine the -15°C. filtrate as well as the room temperature and 0°C. complex fractions from several runs and completely reprocess them with urea.

Most of the mono-, di-, and triunsaturated C-20 vinyls as well as the arachidonate isomer were separated in the complexed fractions obtained at room temperature and at 0°C. The main impurity in the -15°C. complexed fraction, which comprised the main bulk of the methyl arachidonate, was a small amount

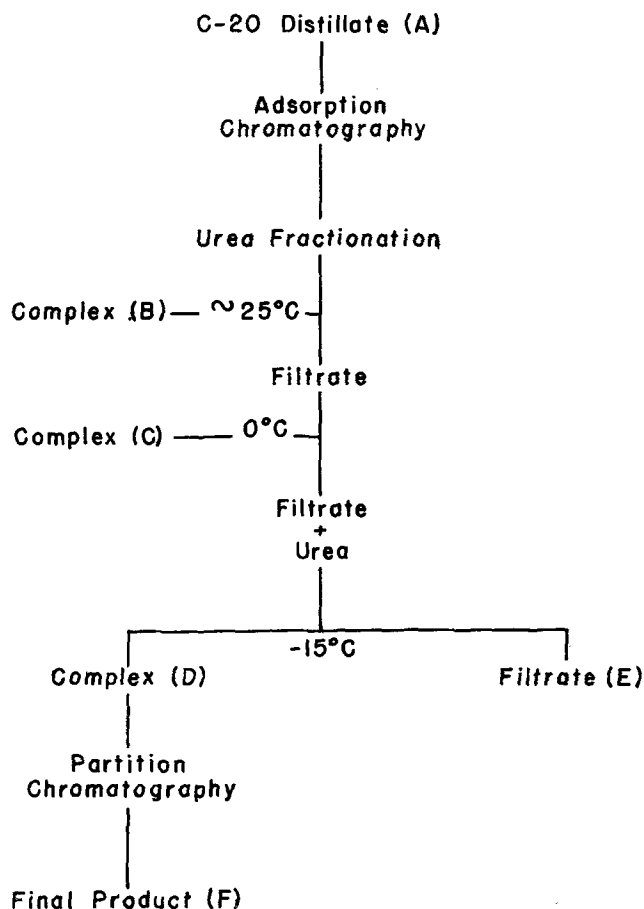

Fig. 4. Purification of methyl arachidonate.

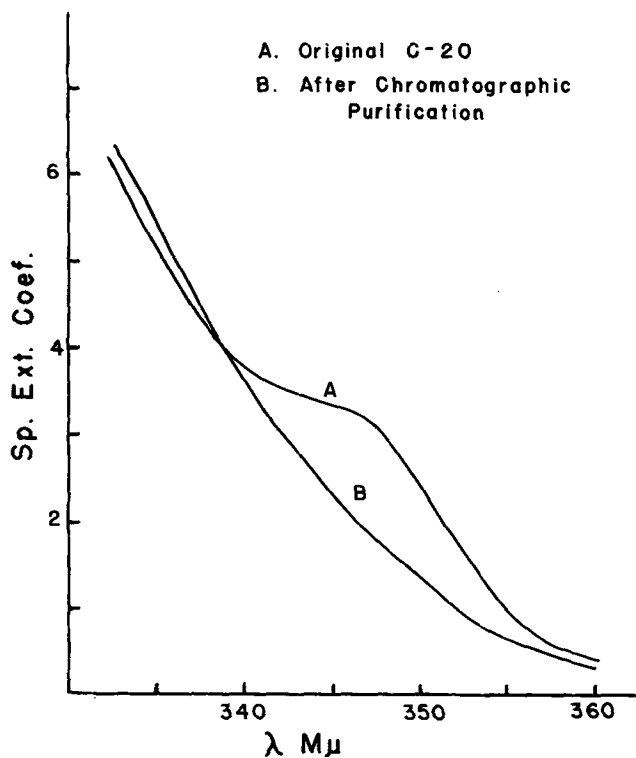

FIG. 5. Ultraviolet spectra of methyl arachidonate concentrates after alkali isomerization.

of methyl eicosatrienoate. The -15°C . filtrate fraction contained the nonurea adduct-forming substances, a small amount of eicosatrienoate, as well as about 87% methyl arachidonate. The GLC analyses and alkali-isomerization analyses of these fractions are shown in Figure 6 and Table III, respectively. Except for the -15°C . filtrate, agreement between the two methods of analysis was fairly good, especially for methyl arachidonate.

The extent of the disparity between the alkali-isomerization analyses and the GLC analyses on the -15°C . filtrate fraction was surprising, but since this fraction contained nonurea adduct-forming material and a relatively low iodine value, it obviously did not contain as high a percentage of methyl arachidonate as indicated by the GLC analyses. Apparently the main impurities in this fraction were not separated by GLC. The alkali-isomerization analysis likewise did not indicate the nature of the impurities, but it did give a more plausible and probably correct

analysis for the methyl arachidonate content of this fraction.

Further purification of the -15° urea-complexed fraction was effected by reversed-phase partition chromatography, using acetonitrile-methanol as the mobile phase and heptane as the stationary phase on a column of nonwetting Celite.

One hundred grams of Hyflo-Celite, made nonwetting by treatment with dichlorodimethylsilane (10), was slurried with 500 ml. of freshly distilled, air-free heptane and poured into a Pyrex chromatographic column 35 mm. in diameter by 750 mm. in length, wrapped with brown paper. The column was gently tapped with a rubber mallet to prevent channels from forming. After most of the heptane had passed through the column, air-free acetonitrile-methanol

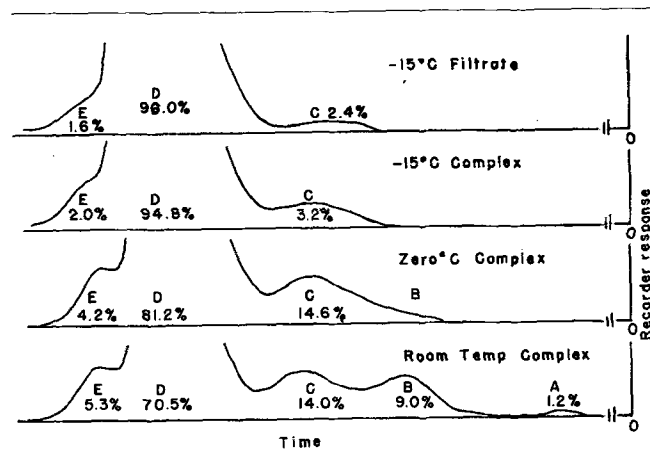

FIG. 6. GLC analyses of fractions obtained by urea fractionation. A = mono, B = di, C = tri, D = tetra, C-20 methyl esters; E = isomeric methyl arachidonate.

(85:15), saturated with heptane, was added to remove the excess heptane. About 90 ml. of heptane remained on the column and served as the stationary phase. Approximately 1 g. of the -15° complex material (96% methyl arachidonate) was added to the column in a small amount of acetonitrile-methanol after all the excess heptane was removed. The eluant was collected in 75-ml. aliquots, evaporated to dryness, and analyzed. The first material emerged after about 150 ml. of the mixed solvent had passed through the column. The material in the first aliquot was usually slightly colored and probably contained some oxidized material. The bulk of the methyl arachidonate came in the third and fourth or the fourth and fifth ali-

TABLE III
Analyses of Fractions in the Isolation of Methyl Arachidonate, Figure 4.

Analyses	Fraction					
	A	B	C	D	E	F
	C-20 distillate	Room temp. complexes	0°C. complexes	-15°C. complexes	-15°C. filtrate	Chromatographic purification
Yield of methyl arachidonate, %	93.0	9.6	11.2	51.0	17.1	44.0
Iodine value (Wijs)	311.3	279.4	302.0	314.2	286.5	317.8
Methyl arachidonate, %	87.4	69.1	82.7	95.9	87.8	99+
Methyl eicosapentaenoate, %	2.7	0	0	0	0	0
Methyl eicosatrienoate, %	6.1	15.3	10.9	3.0	1.6	0
Methyl eicosadienoate, %	5.0	12.4	4.8	2.6	2.6	0
Other constituents, % (difference)	0	3.2 ^a	1.6 ^a	0	8.0	Trace
Diene conjugation, k_{233}	0.61	0.27	0.14	0.16	3.22	0.19
Triene conjugation, k_{233}	0.31	0.06	0.06	0.09	0.08	0.06
Color	Yellow	None	None	None	Yellow	Slightly yellow

^a Methyl eicosanoate.

quots and made up about 90% of the material. Another 300 ml. of solvent were usually passed through the column to recover the remainder of the sample. The lower unsaturated impurities were separated in these fractions. The entire process, after the addition of the sample, usually took about 14 hrs.

Fractionation of the sample was monitored by GLC and iodine value determinations (Wijs). The GLC analyses in this case (Figure 7) were supplied by R. T. Holman of our Institute, using an ionization detector with LAC 446 as the stationary phase. The

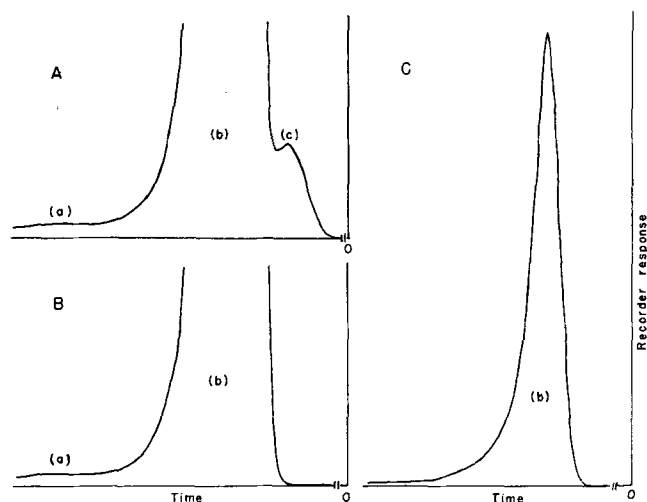

FIG. 7. GLC analyses of methyl arachidonate samples. A, before reversed-phase partition chromatography; B and C, after reversed-phase partition chromatography. Peak (a) is isomeric methyl arachidonate, (b) methyl arachidonate, and (c) methyl eicosatrienoate.

analysis of the purified fraction is compared with the original material in Figure 7 (Curves A and B, respectively). An unusually large sample was applied in this case to make the analysis more sensitive to trace impurities. The results showed that the eicosatrienoate contaminant was completely eliminated, and the only impurity was a trace, probably less than 0.2%, of isomeric methyl eicosatetraenoate. When a normal analysis was made (Curve C, Figure 7), no impurities could be detected. However this preparation had a slight yellow tinge in contrast to the original -15°C . urea-complexed fraction, used as the starting material, which was completely colorless. Thus it probably contained a trace of oxidized material as well as traces of other impurities, which accounted for the slightly lower iodine value (317.8 vs. 318.8). Nevertheless this preparation was believed to be more than 99% pure. It had a refractive index of 1.4799 at 20°C ., and its melting point after hydrogenation, $46.9-47.2^{\circ}\text{C}$., was not depressed in a mixed melting-point determination with methyl arachidate. The infrared spectrum (not shown) presented no evidence of the presence of *trans* unsaturation, diene conjugation, or other structures inconsistent with the generally accepted structure of methyl arachidonate.

Alkali-Isomerization Analysis of Methyl Arachidonate. By using the conditions prescribed by the macro-method of Herb and Riemenschneider (8), the extinction coefficients for arachidonic acid were determined from the analysis of the final preparation of methyl arachidonate. These are compared with the

values reported by Herb and Riemenschneider in Table IV. This also shows the analysis of a somewhat less pure sample of methyl arachidonate (96%) to demonstrate that sample sizes from less than 1 mg. to 75 mg. gave no significant differences in the extinction coefficients in the macro-procedure. Usually micro-methods are employed for the analysis of sam-

TABLE IV
Alkali-Isomerization of Methyl Arachidonate
Extinction Coefficients Expressed for Arachidonic Acid
(15 min., 180°C ., 21% KOH-ethylene glycol)

	Fraction D, Table III					Fraction F Table III	Literature values (8)
Sample weight, mg...	0.49	1.03	31.5	48.1	75.6	53.0	70-80
k_{235}	36.9	38.7	37.5	37.7	36.7	35.5	39.7
k_{268}	44.8	44.5	45.5	45.4	45.0	44.6	48.2
k_{315}	65.3	66.0	68.2	68.2	67.0	71.3	60.6
k_{346}	2.6	2.2	2.5	2.5	2.4	2.7

ples of from 1 to 10 mg. because of the denseness of the glycol-KOH reagent. Application of the macro-procedure to less than 1-mg. amounts was made possible by the use of an ethylene glycol-KOH reagent with improved optical properties. This was accomplished in the preparation of the reagent by allowing the ethylene glycol to cool to below 70°C . before adding the KOH. A sufficient amount of KOH should be added however so that the strength of the reagent can be adjusted by dilution with air-free anhydrous ethylene glycol. If these precautions are taken and the solutions are kept air-free at all times, the reagent will be sufficiently transparent to permit its use with micro-size samples.

The results in Table IV are noteworthy on two accounts. a) Arachidonic acid exhibited an absorption at $346\text{ m}\mu$. This absorption obviously should be considered in calculations of mixtures of fatty acids containing four, five, and six double bonds. b) The relatively large difference between the absorptivities on our arachidonate preparations and those previously reported for this compound (8) is highly significant. These differences were not caused by technical manipulations in the procedure as the absorptivities obtained on two samples of 95% methyl arachidonate by S. F. Herb at the Eastern Regional Research Laboratory in Philadelphia agreed fairly well with our results. The disparity appears to be caused by differences in the degree of purity of the preparations, and the equations for the calculation of fatty acid composition containing arachidonic acid should be revised accordingly.

Location of the Double Bonds. Although the structure of arachidonic acid has been determined (3), it was a matter of interest to see what the periodate-permanganate method of oxidative fission, described by von Rudloff *et al.* (14), would give with this acid. The acid fragments of the oxidation were methylated with diazomethane and analyzed by GLC, using Apeizon L as the substrate on fire brick in a column $\frac{1}{4} \times 36$ in. The column was operated at 85°C . and at a flow rate of 50 ml./min. of helium.

The fragments (after methylation) consisted of two major products, dimethyl glutarate and methyl caproate. The amount of other reaction products was insignificant. On the basis of this and other results showing that the double bonds were methylene-interrupted, it was concluded that the double bonds were located in the 5, 8, 11, 14 positions along the chain.

Nuclear Magnetic-Resonance Spectral Analysis of Arachidonic Acid. The spectrum given by arachidonic acid is presented in Figure 8. The analyses were made

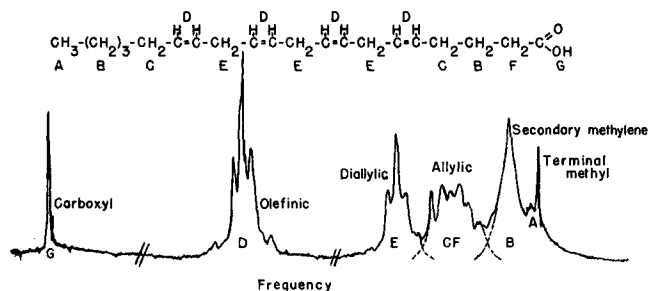

FIG. 8. Nuclear magnetic-resonance spectrum of arachidonic acid. G = carboxyl, $98 \pm 2\%$ of theory (titration); D = olefinic, $97.5 \pm 25\%$ of theory; E = diallylic, $97.5 \pm 35\%$ of theory; CF = allylic, $138 \pm 23\%$; AB = sec. methylene and terminal methyl, $97.5 \pm 11\%$ of theory.

at the Upjohn Company laboratories in Kalamazoo, Mich., by George Slomp Jr. Although there is some discrepancy in the number of allylic structures found in the molecule, there is fair agreement between the calculated values, on the basis of the generally accepted structure for arachidonic acid, and those determined by nuclear magnetic resonance.

Discussion

In the present study the preliminary fractionation was made on the basis of unsaturation. Three groups of acids were obtained: mainly saturated, monounsaturated, and polyunsaturated. The urea fractionation made the separation between the mono- and polyunsaturated acid more complete. In this particular case the material separated by urea fractionation (P_3) could have been combined with P_2 for all practical purposes. Ideally these separations should be more quantitative and should include at least the diunsaturated as another group. This might be partly achieved by a more elaborate scheme of fractionation, but in so doing a large number of fractions of intermediate composition would be obtained. Since these intermediate fractions must also be processed, little would be gained.

The fatty acid composition of hog-liver lipid has been determined by Irvine and Smith (11), but their work was performed before the advent of many modern techniques of analysis and fractionation. Consequently their results, particularly with respect to the more highly polyunsaturated acids, are not as detailed as ours. It should be noted also that our results are not complete in this respect. The structures of the octadecatrienoic, mono-, di-, tri-, and penta- C_{20} acids, docosahexaenoic, docosapentaenoic acids, and the lower unsaturated C_{22} acids, which are believed to be di- and triunsaturated, were not characterized. At the other end of the spectrum, extremely small amounts of some unsaturated acids with less than 16 carbon atoms appear to be present but were not identified. The structures of the palmitoleic, linoleic, and arachidonate isomers also are unknown. The possibility that at least some of the acids detected in trace amounts are artifacts cannot be entirely discounted however.

In our earlier studies, as in the work of others

(13, 16), the phospholipid fraction was used as the starting material for the isolation of arachidonic acid. While the arachidonic acid is more concentrated in the phospholipids, no advantage accrues by making a preliminary separation of this fraction because the same number of steps are required to isolate the arachidonic acid from this fraction as from the total lipid.

It is evident from this study, as well as from others (4, 5, 12), that long-chain polyunsaturated esters with more than three double bonds undergo some alteration during distillation. On redistillation of methyl arachidonate, we observed that the iodine value of the main fraction decreased. While these changes were reduced by use of the distillation technique described, they nevertheless were not eliminated, as evidenced by the presence of material in the distillate which would not form adducts with urea. The nature of the changes caused by heat are not known, but cyclic material is believed to be formed as well as diene conjugated substances, as evidenced by the high absorbance at $233 \text{ m}\mu$ of the nonurea adduct-forming fraction (Table III). The importance of these observations is that it is mandatory to conduct a urea purification after distillation to remove as many of these artifacts as possible.

The "isomers" of methyl arachidonate, linoleate, and palmitoleate may be artifacts, but there is evidence to indicate that they are simple positional isomers, probably of natural origin. First, GLC analyses on material containing these compounds, after hydrogenation, showed that they did not possess odd-numbered carbon chains. In the case of the isomer of methyl arachidonate, the possibility that it was methyl eicosapentaenoate was fairly well eliminated by alkali-isomerization analysis and by the fact that it was not separated from methyl arachidonate by adsorption chromatography. It would not be expected to be methyl eicosatrienoate because of its relative retention-time with respect to methyl arachidonate and because of the fact that isomers with this unsaturation were efficiently separated by reverse-phase partition chromatography (Figure 7). In accord with the observation that positional isomers of unsaturated fatty acid esters exhibit different retention times in GLC (17), these compounds had slightly greater retention times than their corresponding natural isomers. Thus the over-all evidence seems to indicate that these unknown compounds, whose presence was detected by GLC analyses, are positional isomers of their more common counterparts.

Two chromatographic processes were used in the isolation of methyl arachidonate to provide the best possible yield of final product and a purity greater than 99%. It should be mentioned however that a purity of 96% can be obtained in high yields (50-60%) without resorting to any type of chromatographic fractionation, and purities as high as 98% have been obtained in low yields.

Although our final preparation appeared to undergo a slight amount of oxidation in the reverse-phase partition chromatographic process, as evidenced by slight discoloration, it should be possible to eliminate this deficiency by a greater effort to exclude air from the column.

As far as can be determined, the periodate-permanganate oxidative fission method for determining the position of the double bonds along the chain (14)

worked well on arachidonic acid. In other studies, not reported, we found it worked well with monounsaturated acids and docosahexaenoic acid, but satisfactory results could not be obtained with linoleic or linolenic acids.

This study also revealed some limitations of the usual methods of analyses as criteria of purity. It is evident that no single analytical determination is sufficient to establish the purity of a polyunsaturated fatty acid, such as arachidonic acid. Furthermore certain analytical determinations are mandatory. We find that the normal straight-chain polyunsaturated fatty acids containing a methylene-interrupted double bond system up to six double bonds are completely colorless in pure form. Thus the presence of any color denotes the presence of impurities, probably products of oxidative deterioration. On the other hand, oxidized products do not necessarily impart color. They can usually be detected by an elevated spectral absorption at 233 $m\mu$ and/or 268–270 $m\mu$. Thus it is mandatory to determine the ultraviolet absorption characteristics as a check for oxidative deterioration. Another simple but important check for purity is the iodine value by the Wijs method. If this value does not correspond to the theoretical value, it is a virtual certainty that impurities are present. This holds true for fatty acids up to six double bonds. A theoretical iodine value does not necessarily denote absolute purity however. A methyl arachidonate preparation with an iodine value 4 points lower than theoretical (1%) was only 95% pure.

GLC is perhaps the most useful over-all method of analysis, but it has limitations, as evidenced from a comparison with the results of alkali-isomerization analyses on the -15°C . urea-filtrate fraction. In this case apparently some of the sample did not emerge from the column, and so only a portion of it was analyzed. This difficulty may be overcome in various ways, such as the use of interval standards, but the components of the uneluted sample would, of course, have to be analyzed in some other way.

Paper chromatographic analysis was also very useful for monitoring many of the steps in the fractionation. However a single visual spot is only an indication of purity. If used as a criterion of purity, the spot should at least be examined for uniformity by means of a densitometer. Even then conclusions regarding purity must be made with some reservations. In our work, only in certain cases could impurities be detected in preparations of methyl arachidonate of greater than 90% purity.

Alkali-isomerization analyses are particularly useful for detecting and monitoring the most highly unsaturated fatty acids in a mixture. It was used effectively here for detecting and monitoring the removal of the methyl eicosapentaenoate contaminant that was present in the methyl arachidonate preparations. It was more effective in this case than GLC as the isomeric eicosatetraenoate and methyl eicosapentaenoate have virtually the same relative retention-times under the conditions of GLC analysis used. Alkali isomerization also is very useful for following the purification of the most highly unsaturated fatty acid in a mixture and was used for estimating the content of methyl arachidonate at various stages in its purification.

Nuclear magnetic-resonance measurements on arachidonic acid were conducted mostly as a matter of

interest. It is evident that while this technique may serve as a valuable adjunct in determining structural characteristics of fatty acids, its use as an analytical tool is limited on fatty acids of high molecular weight.

Summary

A procedure is described whereby the mixed fatty acids of pork liver lipid are fractionated into groups of acids to facilitate their analysis and isolation. The major acids of pork liver lipid were palmitic 22.9%, stearic 16.8%, oleic 38.5%, linoleic 5.0%, and arachidonic 4.4%. A number of other unsaturated fatty acids were detected in minor amounts, such as isomers of arachidonic, linoleic, and palmitoleic acids. A number of fatty acids of odd-numbered chain length also were detected.

The isolation of methyl arachidonate in a number of preparations of purity ranging from 87 to more than 99% is described. Yields ranged from 44% for the purest arachidonate to 93% for the less pure concentrates. Alkali-isomerization analyses of methyl arachidonate from this source, by the 21% KOH-glycol method, gave appreciably different absorptivities from those previously published.

Various criteria for estimating purity of polyunsaturated fatty acids are discussed in the light of results of the analysis of methyl arachidonate.

Acknowledgments

The authors wish to acknowledge the technical assistance of Paul Schneider, Olavo Romanus, Fred Pusch, and Siret Ener of our staff. We are deeply indebted to both R. T. Holman of this Institute and W. E. Link of the Archer-Daniels-Midland Company for GLC analyses, and to S. F. Herb of the Eastern Regional Research Laboratory for checking our alkali-isomerization method on various methyl arachidonate preparations.

The nuclear magnetic-resonance spectral data were obtained by George Slomp Jr., of the Upjohn Company, Kalamazoo, Mich. We wish to express our appreciation for his splendid cooperation in making these analyses possible.

REFERENCES

1. Ault, W. C., and Brown, J. B., *J. Biol. Chem.*, **107**, 615–622 (1934).
2. Brown, J. B., *J. Biol. Chem.*, **80**, 455–460 (1928).
3. Dolby, D. E., Nunn, L. C. A., and Smedley-MacLean, I., *Biochem. J.*, **34**, 1422–1426 (1940).
4. Farmer, E. H., and Van den Heuvel, F. A., *J. Chem. Soc.*, **1938**, 427–430.
5. Farmer, E. H., and Van den Heuvel, F. A., *J. Soc. Chem. Ind.*, **57**, 24–31T (1938).
6. Hammond, E. G., and Lundberg, W. O., *J. Am. Oil Chemists' Soc.*, **30**, 438–441 (1953).
7. Herb, S. F., and Riemenschneider, R. W., and Donaldson, J., *J. Am. Oil Chemists' Soc.*, **28**, 55–58 (1951).
8. Herb, S. F., and Riemenschneider, R. W., *J. Am. Oil Chemists' Soc.*, **29**, 456–461 (1952).
9. Herb, S. F., and Riemenschneider, R. W., paper presented at the spring meeting of the American Oil Chemists' Society, New Orleans, 1959.
10. Howard, G. A., and Martin, J. P., *Biochem. J.*, **46**, 532–538 (1950).
11. Irving, E., and Smith, J. A. B., *Biochem. J.*, **29**, 1358–1368 (1935).
12. Kyte, R. M., *J. Am. Oil Chemists' Soc.*, **33**, 146–149 (1956).
13. Mowry, D. T., Brode, W. R., and Brown, J. B., *J. Biol. Chem.*, **142**, 671–678 (1942).
14. Von Rudloff, E., *J. Am. Oil Chemists' Soc.*, **33**, 126–128 (1956).
15. Schlenk, H., Gellerman, J. L., Tillotson, J. A., and Mangold, H. K., *J. Am. Oil Chemists' Soc.*, **34**, 377–386 (1957).
16. Shinowara, G. Y., and Brown, J. B., *J. Biol. Chem.*, **134**, 331–340 (1940).
17. Stoffel, W., and Ahrens, E. H., *J. Am. Chem. Soc.*, **80**, 6604–6608 (1958).
18. Tsujimoto, M., *J. Chem. Ind. (Japan)*, **23**, 1007–1010 (1920).
19. White, M. F., and Brown, J. B., *J. Am. Chem. Soc.*, **70**, 4269–4270 (1948).

[Received May 8, 1959]